

PARRA 2,5cm³

OPERATING INSTRUCTIONS

DIESEL

& Glow



* **Displacement 2,49 cc(.15pi)** * **D/S 15x14 mm** * **Weight 147-160 gr**

(ver. 3)

The new *PARRA 2.5 diesel* engine was designed for all aeromodellers who love diesel engines and need a modern quality engine for use in competition and sport flying. It fills the gap left by legendary diesel engines now out of production, but incorporates modern design elements and delivers high performance. The *PARRA*'s initial design has been further developed over two years, with extensive testing by the best racing and combat specialists at the moment. The *PARRA 2.5 Diesel* is made from the finest materials, with precision fits and tolerances made possible by modern machinery and expert workmanship.

A wide range of uses is accommodated by the 3 versions;

SSC .- Steel chromed sleeve and steel piston.

AAC .- Chrome plated aluminium sleeve & aluminium piston with high silicon content.

ABC .- Chrome plated brass sleeve & aluminium piston with high silicon content.

Each engine is supplied with two carburettor inserts allowing optimisation of fuel suction (for aerobatics and combat) or power (for racing). Both versions have modern Schnuerle porting, latest technology two-piece "push-pull" cylinder head/contra-piston assembly and a balanced crankshaft riding in two ball bearings. The prop driver design avoids snagging the opponent's combat streamer cord and minimises ingress of dirt. Careful design has resulted in a rugged long-lasting engine of light weight (AAC version is 147 gr.) that is easy to start and operate.

RUNNING IN

The engine is accurately fitted and adjusted at the factory, so it requires a relatively short running-in period of about 3 to 5 runs of 5 minutes each, allowing it to cool down between runs. Opening the needle valve to 2 ½ turns will allow starting and running during this period at about 60% of peak power. You may see some burnt colour and grey particles in the exhaust oil during the first few runs, indicating that the moving parts are bedding in. The exhaust colour should clean up to a clear yellow colour (a bit like honey), which indicates correct adjustment for good operation. After the fifth run, you can increase engine speed to approximately 95% of peak and it should hold steady RPM. Maintain this slightly under-compressed and rich setting for the first 10 flights.

For Glow AAC & ABC head conversions, add to the head, two 0,10 mm shims for running-in period. Remove shims depending on uses conditions. Nelson head type is more effective than Standard glow head.

FIRST FLIGHTS

It is very important to not overwork or force the engine during initial flights. Set compression to avoid darkened exhaust oil colour. Never black! Darkened exhaust oil indicates over-compressed condition, which generates excess heat and load on the parts. Remember also that if you close the needle in excess, you also reduce the vital oil supply to the engine. Don't hurry to produce high speed performance too early with your engine. Your care and patience now will be rewarded by a long operating life and top engine performance.

FUEL

The fuel should contain not less than 20% castor oil, especially for the SSC version. The recommended mix for diesel is: 20% Castor Oil, 33% Diethyl Ether, 45.2% Kerosene and 1.8% Ethyl Nitrate or DII.

The recommended mix for glow is 80% methanol and 20% Castor Oil. Nitromethane is not necessary but it can be used 5 – 10 %.

RECOMMENDED PROPELLERS

The *PARRA 2.5 diesel*'s flexibility allows it to satisfactorily operate on a wide range of propellers. Some experimentation will give optimum performance for your application. The propeller should be the most rigid possible (filled nylon or wood) and balanced in order to prevent vibration. We recommend 8x4 or 8x6 for running in. The following propellers are a good starting point:

Combat – 8x4, 8x5, 8x6, 7x6 depending on requirements or specific combat class

Racing - APC 7x6, works well

Sport Flying – 8x4, 8x6

MAINTENANCE

All parts can be removed without force. If you do not have experience, don't totally dismantle your engine. For cleaning dirt from inside the engine, it is normally enough to remove the head by unscrewing the clamp ring and unscrewing the rear cover. Wash with kerosene or ethyl alcohol. Then lubricate it with a few drops of machine oil into the cylinder and rear ball-bearing before reassembly. Use nothing more aggressive than a plastic scrubber to clean carbon from the head or piston crown, rinsing well before reassembly.

For further disassembly, please visit our website www.clubtamaran.com where you can find technical solutions and tips for maximum enjoyment of your PARRA 2,5 diesel engine.

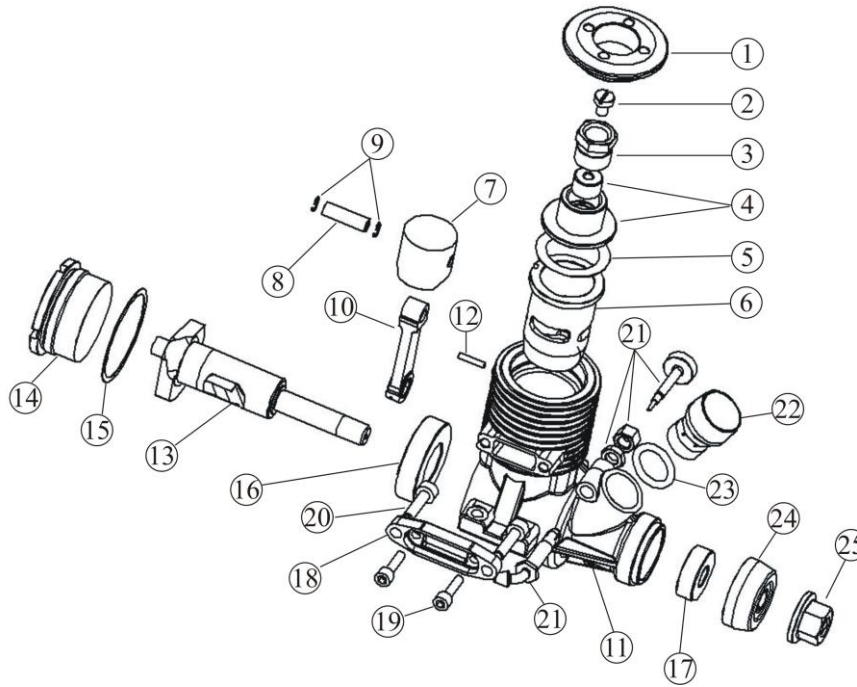

No.	Part	Part No.	No.	Part	Part No.
1	Threaded clamp ring	2501	18	COMBAT collector	2518COM
2	Left hand thread screw	2502D	19	Screws M2x0,8 mm (2)	2519
3	Compression screw	2503D	20	Screws M3x10mm (2)	2520
4	Head with conterpiston	2504D	21	Carburettor	2521
4	Glow Head	2504G	21	Carburettor COMBAT	2521COM
5	Head shim	2505	22	Venturi 3,5 mm	252235
6,7,8,9,10	Complete liner STEEL - D & G	25067S	22	Venturi 4,5 mm	252245
6,7,8,9,10	Complete liner AAC- D & G	25067A	22	Venturi COMBAT 4 mm	2522COMG
8	Wirst pin	2508	22	Venturi COMBAT 3,4 mm DIESEL	2522COMD
9	G- ring	2509	23	O-ring	2523
10	Connecting rod	2510	24	Prop drive & drive shaft	2524
10	AAC Connecting rod	2510A	25	Auminium propeller nut	2525
11	crankcase	2511	26	R/C Carburettor + fixing screw	2526
12	Sleeve stop	2512	27	Silencer + adaptader	2527S
13	crankshaft	2513	27	Extra silencer + adaptor	2527SM
14	Rear cover	2514	27	tongue + adaptador	2527T
14	Rear cover CHROME	2514CR	27	COMBAT silencer	2527COM
15	Rear cover gasket	2515	28	Simple head wrench	2528
16	Rear ball bearing 12x24x6 mm	2516	29	Multi wrench	2529
17	Front ball bearing 6x15x5mm	2517	30	Glow plug	2530

